

# HYDRAULIC EXCAVATOR **SY365C**<sub>T4f</sub>



**SANY**  
AMERICA INC.

**Rated Power**

275 hp / 205 kW

**Operating Weight**

79,860 lb / 36,224 kg

**Dig Depth**

24' 2" / 7377 mm

**Bucket Breakout**

43,163 lbf / 192 kN

# SY365C DIMENSIONS & SPECIFICATIONS

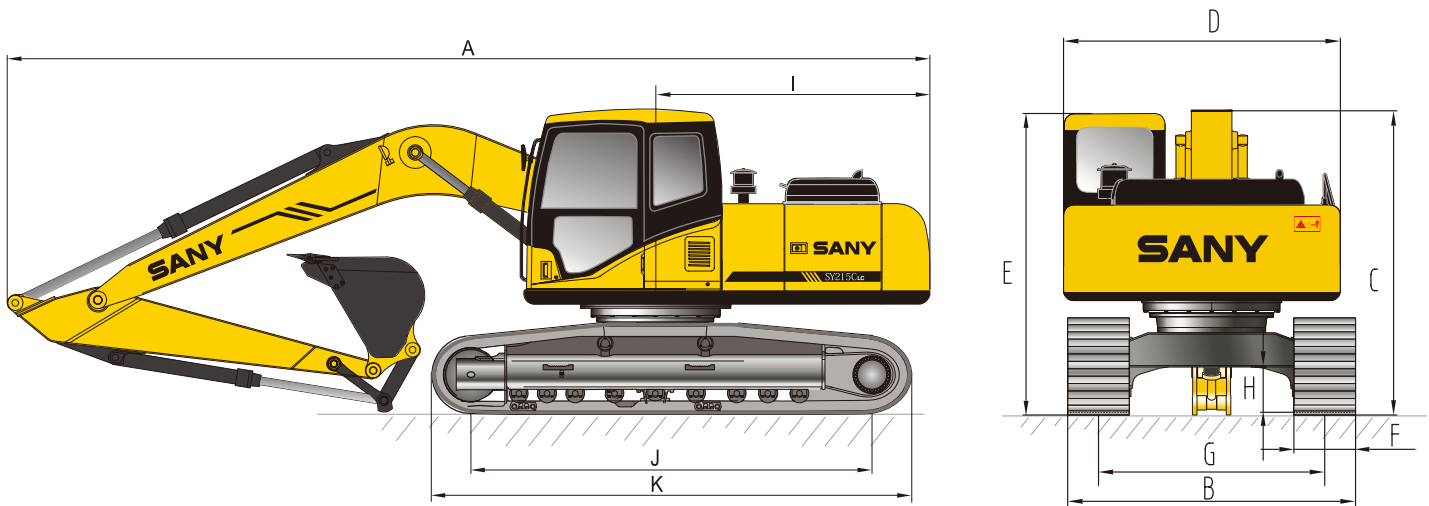

## OVERALL DIMENSIONS

A. Transport Length	36' 5" (11100 mm)
B. Transport Width	11' 2" (3390 mm)
C. Transport Height	11' 9" (3600 mm)
D. Upper Width	9' 11" (3020 mm)
E. Cab Height	10' 4" (3140 mm)
F. Track Shoe Width (standard)	2' 7" (800 mm)
G. Track Gauge	8' 6" (2590 mm)
H. Minimum Ground Clearance	1' 9" (550 mm)
I. Tail Swing Radius	10' 10" (3300 mm)
J. Length Center Idler to Center Sprocket	13' 7" (4140 mm)
K. Track Length	16' 7" (5055 mm)
Boom Length	21' 4" (6470 mm)
Arm Length (standard)	10' 5" (3178 mm)

## MACHINE PARAMETERS

Operating Weight	79,860 lb (36,224 kg)
Engine Type	Cummins QSL9 T4 final
Engine Max Power (Gross)	286 hp (213 kW) @ 1850 rpm
Engine Max Torque	895 lbf (1213 Nm) @ 1500 rpm
Engine Displacement	542 in <sup>3</sup> (8.9 liter)
Main Pump Flow	2x 95 gpm (360 lpm)
Swing Speed	9.8 rpm
Travel Speed	2.1/3.2 mph (3.4/5.2 km/h)
Tractive Effort	48,109 lbf (214 kN)
Max Arm Digging Force (ISO)	37,835 lbf (168 kN)
Number of Upper Rollers	2
Number of Lower Rollers	9
Fuel Tank Capacity	143 gal (540 liter)
DEF Tank Capacity	5 gal (19 liter)
Hydraulic Tank Capacity	90 gal (340 liter)
Cooling System Capacity	12.5 gal (48 liter)
Engine Oil Capacity	7.7 gal (29 liter)
Ground Pressure (31.5"/800mm shoes)	7.1 psi (48.7 kPa)

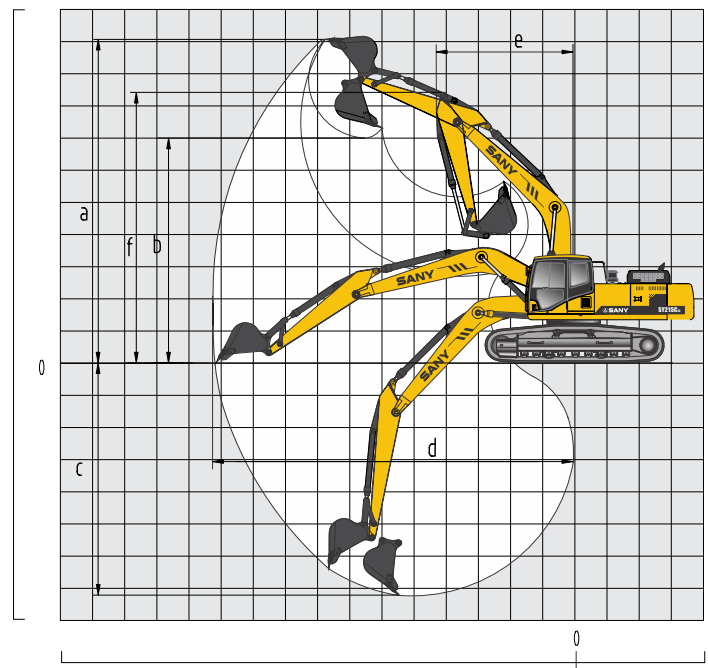

## WORKING RANGE

a Maximum Digging Height	33' 2" (10110 mm)
b Maximum Dumping Height	23' 4" (7100 mm)
c Maximum Digging Depth	24' 0" (7327 mm)
d Maximum Vertical Wall Digging Depth	21' 3" (6480 mm)
e Maximum Digging Reach	36' 5" (11090 mm)
f Minimum Swing Radius	14' 2" (4310 mm)
g Maximum Height at Minimum Swing Radius	27' 10" (8480 mm)



**SANY**  
AMERICA INC.

318 Cooper Circle  
Peachtree City, GA, 30269  
www.sanyamerica.com